

flipIT Lift® Installation

DETERMINE WHERE ON DESK YOU WOULD LIKE THE CUT OUT.
(MAKE SURE CUT OUT WON'T COMPROMISE DESK TOP INTEGRITY)

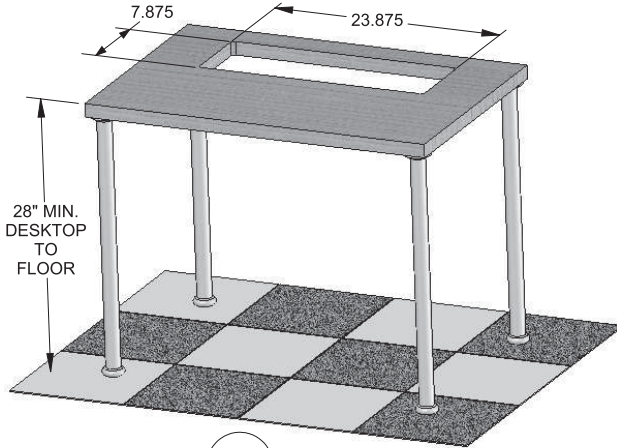

1

MONITOR MOUNTING BRACKET WITH OUT TILT

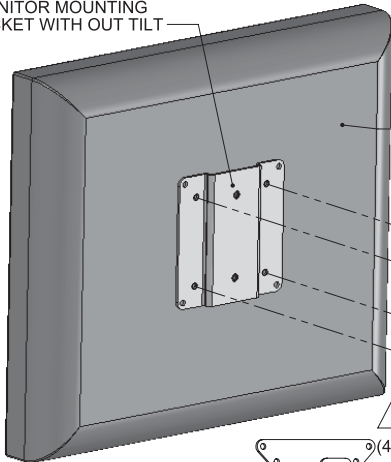

TOTAL MONITOR AND LID WEIGHT RANGES:
5-15 LBS.
&
15-25 LBS.

ATTCH MONITOR WITH
(4) 4mm x 12mm PHPR SCREWS PROVIDED

MONITOR MOUNTING BRACKET WITH TILT

MOUNT THE NON-TILT OR THE TILT MONITOR BRACKET TO THE BACK OF YOUR MONITOR. 75mm OR 100mm PATTERN PROVIDED.

4

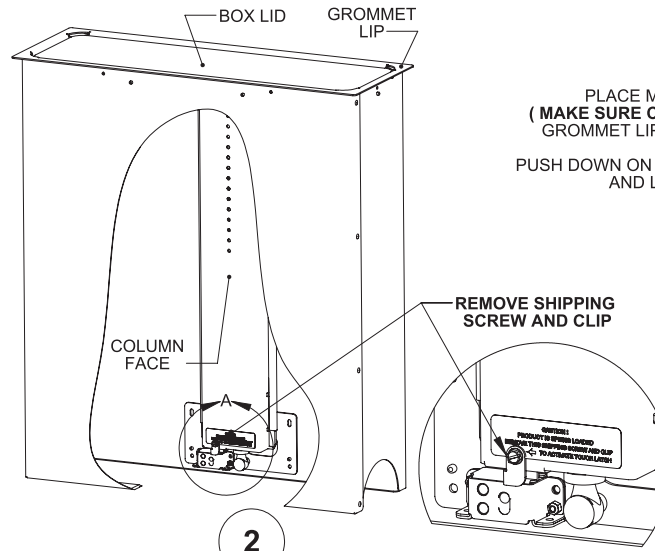

2

REMOVE SHIPPING SCREW AND CLIP

DETAIL A
SCALE 1 : 3

TAKE MONITOR AND PLACE TOP EDGE JUST BELOW THE BOX LID AND ALIGN THE 2 MOUNTING HOLES WITH THE 2 NEAREST HOLES ON THE VERTICAL COLUMN AND INSTALL #10x3/8 SEMS SCREWS (2 SCREWS PROVIDED)

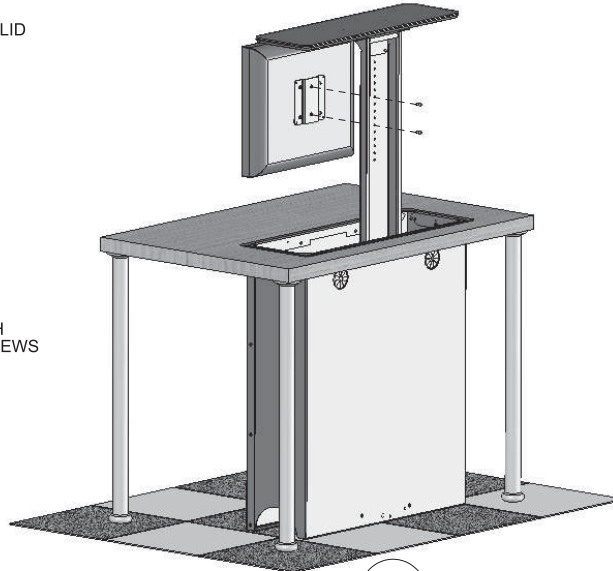

5

PLACE MONITOR BOX INTO CUT OUT
(MAKE SURE COLUMN FACE IS TOWARDS USER)
GROMMET LIP SHOULD SIT ON DESK SURFACE

PUSH DOWN ON BOX LID TO RELEASE TOUCH LATCH AND LET COLUMN FULLY RAISE

INSTALL (6) #6x1" TRUSS HEAD SCREWS, THRU GROMMET HOLES INTO DESK CUT OUT

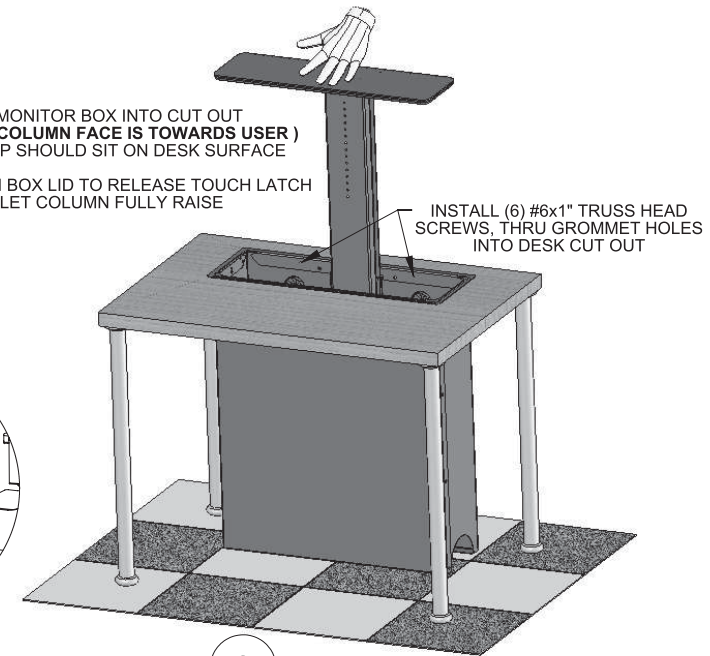

3

MAKE SURE CORDS AND CABLES HAVE A PROPER LOOP TO ALLOW MONITOR FULL UP AND DOWN TRAVEL
KEEP ALL CORDS AND CABLES AWAY FROM TRACK AND TOUCH LATCH

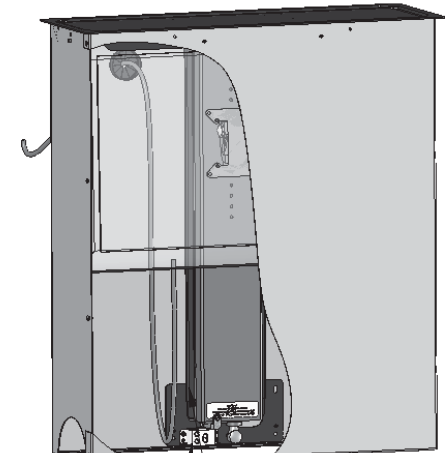

TOUCH LATCH
TRACK

6